

Designing Stand-Alone Microgrid Hybrid Solar/Wind Energy Systems and Grid-Connected Smartgrid Hybrid Solar/Wind Energy Systems

Dominick Lauria
University of Hartford
dlauria@hartford.edu

Sarah Lamb
University of Hartford
slamb@hartford.edu

Akram Abu-Aisheh
University of Hartford
abuaisheh@hartford.edu

Abstract

The design and implementation of microgrid technology is a leading trend in modern energy management. A microgrid is a multi-input, standalone energy system that is capable of operating in parallel with or independent from the main electrical grid. The prefix “micro” can be misleading, however, as most current technology can be scaled with reasonable precision to meet the energy demands of the end consumer. Modern microgrids take in energy from a variety of sources – in this case, sunlight, wind, and a main electrical grid – and facilitate not only its conversion into electrical energy, but also the demand management, storage, and generation associated with the system’s output.

This project focuses on the design and simulation of a 48-V rated stand-alone microgrid that is supplied primarily by photovoltaic (PV) panels and a wind turbine, but which also has the capability to tie in to a main electrical grid. A system of this size should be able to supply power for up to two average-size homes or office buildings. The most important objectives of this project are the selections of an appropriate PV array and wind turbine, the selection or design of a charge controller, and the design of the system’s renewable energy converter.

Introduction

A basic overview (block diagram) of the intended microgrid system is shown in Figure 1. For the purposes of this project, the most significant parts of the system are the PV array, wind turbine, and renewable energy converter blocks. The project will focus on the design considerations and specifications for a grid connected PV-wind hybrid system with battery back-up.

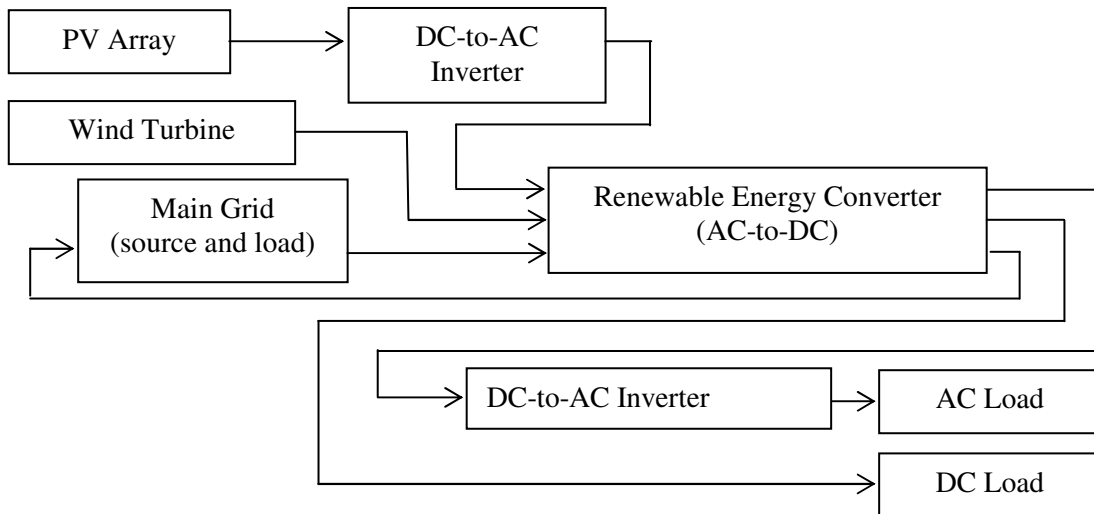

Figure 1: Block Diagram of a Smart Microgrid

PV panels are photoelectric devices that take in light energy from the sun and convert it into a DC voltage output. This output voltage can be regulated by applying it to a DC-DC converter, which will adjust the magnitude of the voltage. In the case of a PV panel specifically, any DC voltage output can be “dumped” into a battery bank and stored for future use. The direct or DC-DC converted output voltage can also be applied to an inverter, which will yield an overall AC output voltage.

Wind turbines are electromechanical devices that transfer the mechanical energy of a spinning rotor into an AC voltage output. Since the generated voltage is AC, a transformer can be used to step-up or step-down the voltage in order to obtain the desired voltage level to power the load.

PV panels and one or more wind turbines will be selected from commercially available models, in order to meet the design specifications of the project. However, the renewable energy converter must be uniquely designed and configured to meet the exact parameters of all other system components. For a multi-source renewable energy system, such as the one studied here, the renewable energy converter is often designed to include the DC-to-AC inverter and the DC-to-DC converter – which are separated in the block diagram – into one coherent circuit.

There are two likely configurations for this system’s renewable energy converter: (1) a Cuk converter paired with a SEPIC converter, or (2) a boost converter paired with an inverter. The advantages, disadvantages, and standard performance of each type of converter will be analyzed, and the results of these analyses will be applied to the design of a converter that is tailored to the exact needs of the microgrid.

Once the components of the microgrid system have been selected (PV array, wind turbine) and designed (renewable energy converter), the system will be analyzed – both as a whole and as the sum of its parts – using Matlab and Simulink software. Simulations will focus on input and output power, such that the overall efficiency can be calculated in each case.

Flat Panel Photovoltaic System Considerations

A flat panel photovoltaic (PV) system will generate DC electricity in direct proportion to the amount of surface area that is exposed to sunlight. Modules are designed to supply this electricity at a certain voltage; however the current produced is directly dependent on how much light is absorbed by the system. Any desired combination of voltage and current can be produced by connecting an array of panels in a series or parallel topology. The PV panels themselves are comprised of modules, which are in turn comprised individual PV cells. Each PV cell is actually a very thin semiconductor wafer of photosensitive silicon or selenium that has been “doped” with boron (positively-charged, p-type material) and phosphorous (negatively-charged, n-type material) to increase its electrical conductivity to a level that is sufficiently for the cell to distribute charge and induce an electric field.

By themselves, PV modules or arrays do not represent an entire PV system. Systems also include structures that point them toward the sun and components that take the direct-current electricity produced by modules and "condition" that electricity, usually by converting it to alternate-current electricity. PV systems may also include batteries and/or back-up generators. These items are referred to as the balance of system (BOS) components. Combining PV modules with BOS components creates an entire PV system. A system is usually everything needed to meet a particular energy demand, such as an industrial appliance, the lights in a home, or – if the system is large enough – the electrical demand of an entire community. A BOS may also include any or all of the following: a renewable energy credit revenue-grade meter, a maximum power point tracker (MPPT), a battery system and charger, a GPS solar tracker, energy management software, solar irradiance sensors, and an anemometer.

Flat panel systems account for the majority of renewable energy installations in the United States. At any given location on a clear day, the amount of sunlight striking the earth’s surface is equivalent to approximately 1,000 watts of power per square meter [10]. A single, flat panel is composed of at least 600 PV cells and can produce between 5 to 300 volts of electrical power depending on sunlight exposure. One panel alone is rarely sufficient for home or industrial applications, so multiple panels are wired together in series, parallel, or series-parallel topologies to create the large PV arrays that most people associate with “solar power.” Most commercially available PV systems can deliver voltage magnitudes in multiples of 12 volts and current magnitudes in multiples of 3 amps. Roof installations of PV arrays – facilitated by simple and versatile mechanical brackets – are most common among home and business consumers, although an increasing number of business/industrial consumers are installing solar panels on large tracts of open land – such as land that has been contaminated and is un-developable.

The performance of a PV system module is measured as a function of its solar cell electrical performance, degradation factors associated with array design and assembly, environmental versus operating temperatures, and array power output capability. The industry standard is to report a PV module's performance as a peak watt rating. The peak watt (Wp) rating is determined by measuring the maximum power of a PV module under laboratory conditions of relatively high light, favorable air mass, and low cell temperature. But these conditions are not typical in the real world. Therefore, researchers may use a different procedure, known as the normal operating cell temperature (NOCT) rating. In this procedure, the module first equilibrates with a specified ambient temperature so that maximum power is measured at a nominal operating cell temperature. This NOCT rating results in a lower watt value than the peak-watt rating, but it is probably more realistic. However, neither of these methods is designed to indicate the performance of a solar module under realistic operating conditions. Another technique, the AMPM Standard, involves considering the whole day rather than "peak" sunshine hours. This standard, which is intended to address the practical user's needs, is based on the description of a standard solar global-average day (or a practical global average) in terms of light levels, ambient temperature, and air mass.

The feeding of electricity from a PV system back into the grid requires the transformation of DC power into AC by a synchronizing grid-tied inverter. Modern inverters used in this capacity are quite effective; they allow the PV array to operate at the maximum power point (MPP) under all conditions, they generate AC output current in phase with the AC utility grid voltage, and they achieve a power conversion efficiency of nearly 100%. In some cases, the inverter even provides energy storage to balance the power difference between the PV array (DC power) and the AC (time-domain) power of the grid.

Wind Turbine System Considerations

A wind power system relies on the fluid flow of air to apply a force on its rotor blades, causing the turbine to rotate; the system will then convert the rotational kinetic energy of the turbine into DC electricity via an electric generator. The two critical factors for power generation are wind speed and the quality of wind. Environmental (buildings) and atmospheric factors (turbulence) can interfere with the available wind; thus wind turbines are most efficient when constructed in elevated, open areas.

The primary difference between wind and solar systems is that wind systems convert pure mechanical (kinetic) energy into electrical power, whereas solar systems rely on chemical reactions and thermal properties to generate electrical power. Consequentially, the physical design of a wind turbine is far simpler than something like a PV array. A wind turbine's most visible components are its blades, which are aerodynamically designed to capture the maximum amount of the wind's kinetic energy. The blades turn a rotor, which in turn rotates a shaft. Ultimately, the most important part of any wind turbine is its generator, which is driven by the shaft and functions similarly to an electric motor. The generator consists of a rotor and a stator; the wind turbine's shaft is connected to the rotor such that it causes the rotor to spin, creating (inducing) a rotating magnetic field within the stator (stationary portion

of the motor). This induced magnetic field (B) effectively rotates the North-South poles of the stator, which “pulls along” the loops on the armature (rotor) windings, ultimately causing the armature to “follow” the rotation of the field and create an electromotive force (E) that is harnessed as electrical power.

An AC generator will produce AC electricity that can be directly transferred into an electrical grid for consumption. A DC generator will produce DC electricity that must be inverted into AC before it can be transported or consumed. Not only is AC power the primary source for home and business/industrial consumption, but it is also much easier and safer to transport over power lines without losing efficiency than DC power. Depending on the needs of the consumer, the final AC output of a wind turbine system will pass through an inverter to stabilize its voltage, current, and frequency to the local electrical grid’s standard, and will then be connected to the grid in one of three ways: (1) grid connection only, (2) grid connection with battery back-up, or (3) grid connection with generator back-up.

When a wind turbine is directly connected to the grid (option 1), the grid will become the consumer’s primary source of electricity on days with very little wind. The addition of a battery back-up (option 2) allows a certain amount of the turbine’s excess energy to be stored in the batteries as DC potential energy, but requires the inclusion of a controller unit between the turbine’s output and the batteries to regulate the flow of current to and from the batteries. A back-up generator (option 3) can be used in place of or in conjunction with a battery back-up; the generator’s main purpose is to keep the battery pack charged during periods of main grid failure (ex: utility power outage) and no wind. Depending on the generator’s configuration, it could also be used as the home’s or business’ chief source of power during an emergency as given in Figure 2.

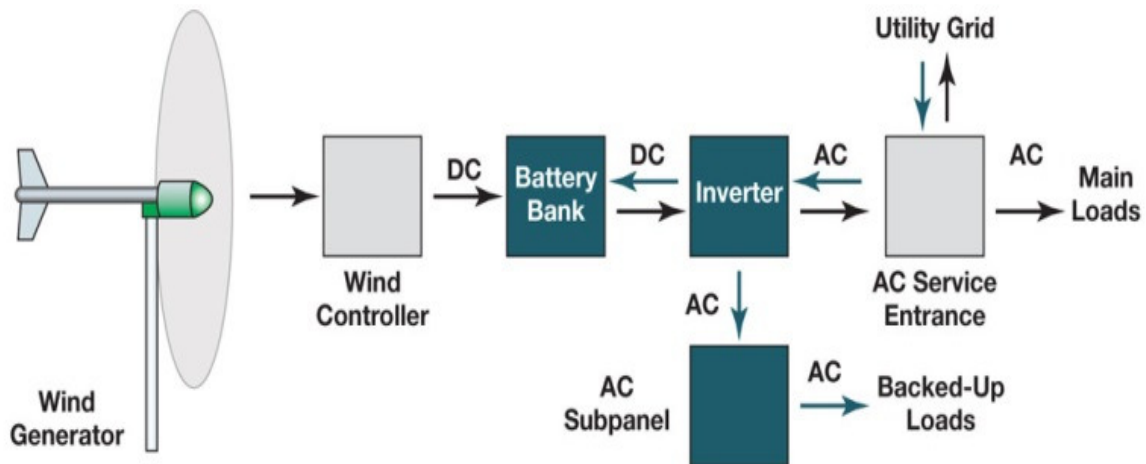

Figure 2: Wind Power System with Back-Up (Source: [Home Power online](#))

There are two major challenges to using wind power systems: the supply of wind and the logistics of wind-generated electricity transportation. Wind is a naturally

intermittent resource, and thus does not always blow when electricity is needed. Wind cannot be stored (although wind-generated electricity can be stored, if batteries are used) and not all winds can be harnessed to meet the timing of electricity demands. Some of the most consistent wind sites are often in remote locations, far from areas of high-demand electricity areas, so once power is generated, it must be transported over large distances and difficult terrain.

Wind turbines of any scale have relatively little impact on the environment, especially when compared to fossil fuel power plants. Consumers living or working near wind farms occasionally express concern over the noise produced by the rotor blades of a large wind turbine, the degradation of their view, and the potential for flying wildlife mortality (birds, bats, etc.). However, it is important to note that most of these issues have been resolved (or are in the process of being resolved) through technological development and improved site planning protocols for large-scale wind power operations.

The major advantage of wind power applications is that they meet the basic power needs of remote areas that are not yet grid-connected. Increasingly, wind systems are being paired with PV systems to create a hybrid topology that is nearly 100% grid-independent. The benefits of hybrid systems for remote areas and/or developing regions of the world are immense.

Hybrid Energy System Considerations

When a reliable grid can be accessed from the location at which renewable energy sources are being used, it is common for excess power generated by those renewable sources be fed into the main power grid. This allows consumers to save money on their electric bills because they are generating power for the electric company. Feeding some amount of renewable-sourced power back into the grid is also a common practice because batteries are one of the most expensive components in renewable systems' designs. Batteries take up space, need to be properly stored, require extra circuitry for control purposes, and even after all of that, they will still eventually need to be replaced.

Although grid connection is a more common practice than battery storage, there are some challenges and considerations to take into account when connecting a renewable system to the main grid. The first challenge is making sure that the hybrid system will be able to reliably output the same voltage and frequency, so as to input that voltage and/or frequency into the grid on a continuous cycle. This is especially important for the grid side of the system, because if the voltage and frequency are not what they needs to be, then there will be a loss of power quality within the grid.

Another consideration is determining at which point in the grid to insert the renewable-sourced power. If a large amount of power is being generated, then transmission line insertion is the best location because the voltage in those lines averages 500-kV, depending on where the transmission lines are located. If a small amount of power is being generated, then the distribution lines are the best place for insertion. [11]

It is important to note that any energy generated through small renewable energy generators cannot be directly connected to the grid. An interface is required between the generation system and the utility distribution grid. For PV systems, an inverter is required; for wind and hydro systems, an induction generator is required. Power electronic converters are also used to interface most of the distribution grids. Used alone, these converters will inject harmonics into the system, often resulting in poor power quality for the end consumers. Thus, harmonic filters must be added to overcome any harmonics. There is one notable exception to this rule: If a pure sine wave inverter is being used, then a harmonic filter will not be required because it is already built into the inverter. In contrast, square wave inverters and modified sine wave inverters both require harmonic filters. For induction generators, voltage flickering may occur, but can often be reduced by utilizing soft-starting mechanisms for the generator itself.

A common circuit to utilize in grid connections is a phase locked loop (PLL). PLLs are circuits that can quickly and accurately detect the phase angle of the grid voltage. By use of a PLL, proper regulation of the power flow between a renewable source and the grid can be achieved. Four industrially standardized examples of PLL circuits include: synchronous reference frame (dq PLL), stationary reference frame ($\alpha\beta$ PLL), decoupled synchronous reference Frame (DSRF PLL), and decoupled stationary reference frame [11].

A major design consideration with any inverter-based distribution grid interface is to configure the interface in such a way that if the main power grid falls offline, the inverter also shuts down. If the inverter does not shut down, it will pose a significant high-current hazard to any electrical maintenance worker who attempts to restore grid power. Therefore, all sources that feed power into the main grid must be shut down without question any time the main power grid goes down, both for safety purposes and to comply with the National Electric Code's (NEC's) requirements.

Hybrid System with PV Array and Wind Turbine

In a PV-wind hybrid system, the power generated from both wind and solar components is stored in a battery bank for later use, thus increasing the reliability of the system. In some cases, the size of the battery storage may be slightly reduced compared to a pure-solar or pure-wind system, because the system is capable of generating power from more than one source.

Wind speeds are often low in periods when the sun resources are at their best (summer). The wind is often stronger in seasons when there are less sun resources (winter). Even during the same day, in many regions worldwide or in some periods of the year, there are different and opposite patterns in terms of wind and solar resources. And those different patterns can make the hybrid systems the “best of both worlds” for power generation.

One potential drawback of the hybrid PV-wind systems is that they carry a significantly higher up-front cost than pure-solar or pure-wind systems. However, the PV-wind hybrid

system offers the greatest return on investment (ROI) in terms of output and performance achieved per dollar invested.

Renewable Energy Converter for PV-Wind Hybrid System

There are two renewable energy converter topologies that are overwhelmingly prevalent in existing industrial applications: (1) a Cuk converter paired with a SEPIC converter, or (2) a boost converter paired with an inverter.

For a Cuk-SEPIC hybrid topology, the pairing of the two converters is possible because the existing diodes are reconfigured such that the SEPIC converter shares the Cuk converter's output inductor as given in Figure 3 [11]. This topology is advantageous because it does not require any low-pass filters between the DC inputs and the hybrid converter, which were utilized in previous designs to eliminate high-frequency harmonics.

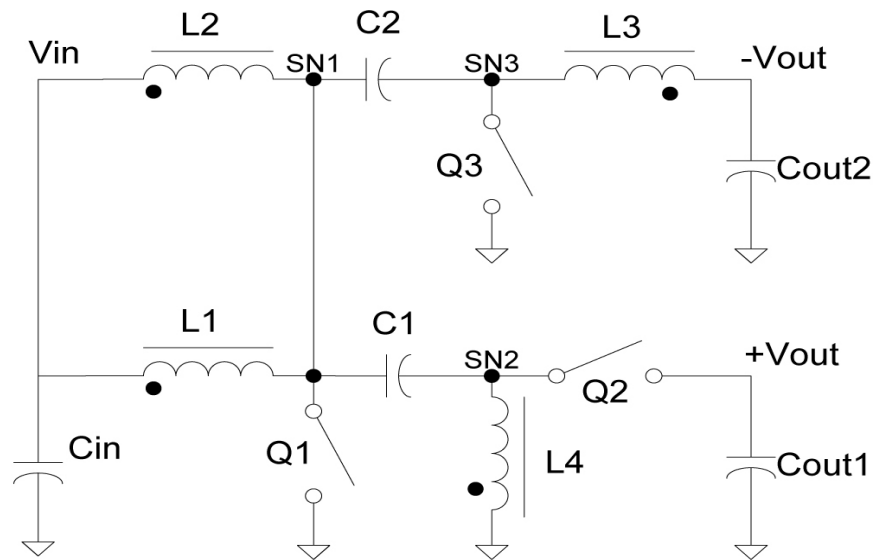

Figure 3: Cuk-SEPIC Circuit Integration (Source: Sumathi, Kumar, and Surekha)

A Boost-Inverter hybrid is conceptually simpler – amplify the input DC voltage with the Boost converter, and then invert it to an AC signal to drive the load – but mechanically more complex. The converter and inverter must be constructed in parallel to each other, which decreases the system's overall efficiency (measured in terms of power transfer, P_{out} / P_{in}).

An existing industrial system similar to the block diagram shown in Figure 1 was recently patented by the US Department of Energy, via a research team at the University of Arkansas [7]. This system, is capable of consolidating multiple levels of DC input into a single, stable AC signal. The system is revolutionary because it uses a multiple square wave input design and thus can be contained entirely in a small, high-frequency transformer. However, it has yet to be introduced to the US commercial market.

With consideration given to the practical advantages and disadvantages of each converter topology, as well as to the commercial availability of components in the US, it is advisable to use the Cuk-SEPIC converter for this and any stand-alone microgrid application.

Within the Cuk-SEPIC converter, it is necessary to include integrated circuits for both AC-to-DC rectifiers and DC-to-AC inverters. Depending on the characteristics of a system's input voltages (AC or DC, magnitude, and phase), rectifiers will be needed to step up or step down the voltage so that it is suitable to drive the load. Similarly, inverters will be needed to transform any DC signal into an output that is compatible with an AC load.

There are two widely-accepted rectifiers for renewable energy applications: (1) a switching power supply, and (2) integrated microcontrollers. The latter option increases the cost of the rectifier considerably and does not yield noticeably better results, so the use of a switching power supply is recommended for most renewable energy applications.

In terms of any DC-to-AC conversions, the use of a full-bridge inverter is overwhelmingly favored for renewable energy applications, although a half-bridge inverter may also be used depending on the specifications of the system and the availability of components. Any renewable energy system that includes a PV array must also include an inverter, due to the array's DC output and the strong likelihood of an AC load or main grid connection.

A full bridge inverter given in Figure 4 takes in a constant, DC signal and generates an oscillating AC signal as given in Figure 5.

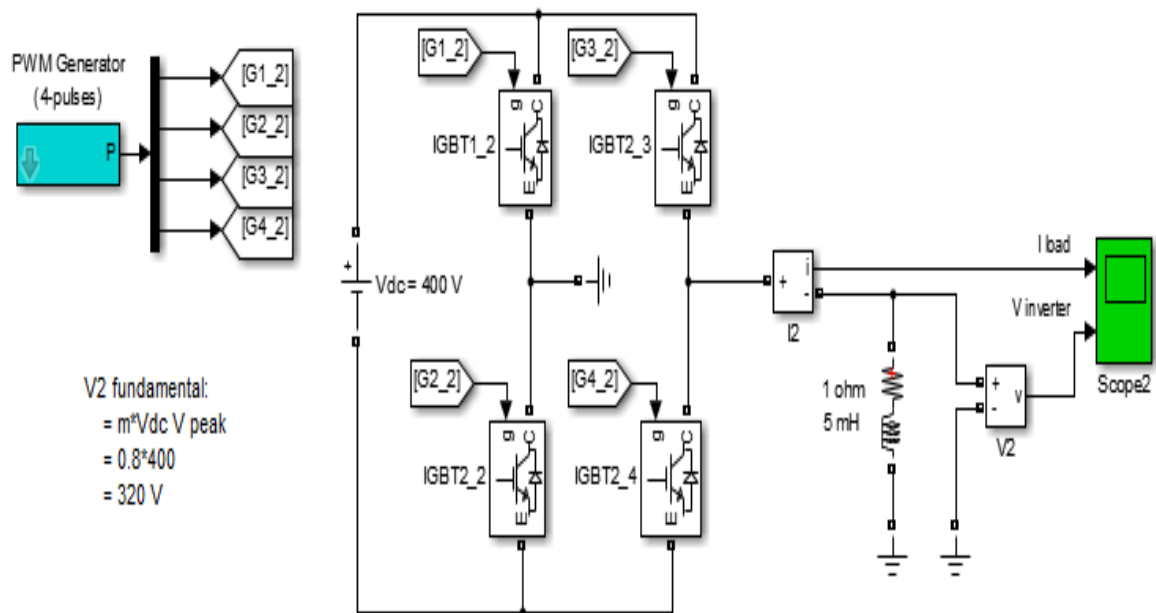

Figure 4: Simulink Model of Full-Bridge Inverter

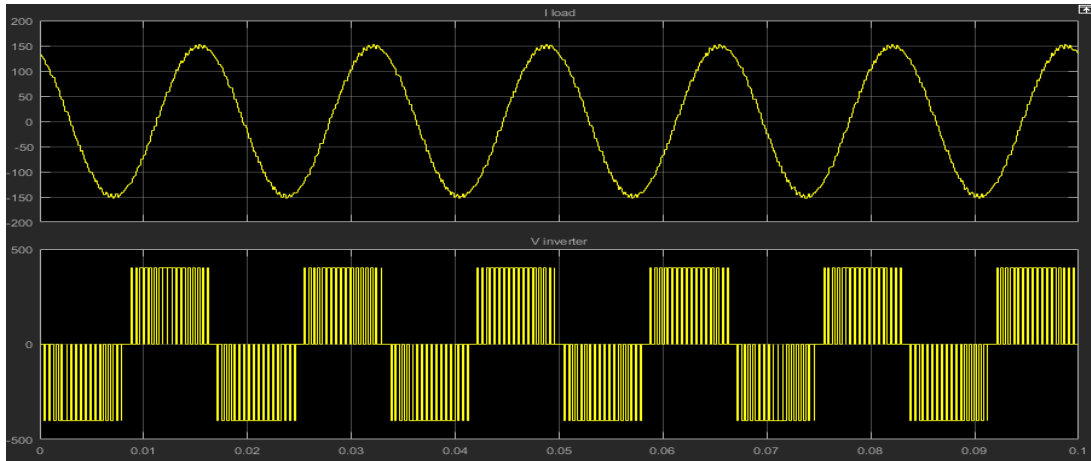

Figure 5: Simulink Scope for Full-Bridge Inverter Output

For commercial applications, an AC oscillation frequency of 60-Hz is preferred. The quality of an inverter is determined by the smoothness of its 60-Hz signal, with better quality inverters yielding smoother signals. The more noise that is present in an inverter’s output signal, the less power transfer that inverter can achieve. In general, a full-bridge inverter will output a higher quality signal than a half-bridge inverter, which is why full-bridge inverters are preferred for renewable energy and power electronics applications.

Battery Back-Up Considerations

When operating a PV, wind, or hybrid system, there are times when more power will be generated than what is needed to drive the load. In such a case, the extra power must either be fed into the main grid or captured and stored in a battery bank. Even in the case of a grid-connected system, a battery back-up is often preferred (in addition to the grid connection) because it allows the system to remain self-sufficient during non-operational hours.

From a physical perspective, a battery is an electrochemical device that stores DC power and undergoes chemical reactions in order to add to (charge) or release (discharge) its initial level of electric charge. The batteries used in renewable systems are referred to as “secondary batteries,” because they are used as a secondary energy source and can easily be charged when extra power is present. It is important to distinguish these from “primary batteries,” which cannot be used for renewable systems because they must start with a full charge and can only be discharged while the system is in operation.

One very important consideration for the selection of a renewable system’s secondary battery is how much current the load will draw from the battery bank. The maximum current drawn cannot exceed what the battery is rated for, otherwise the chemical reactions that occur inside the battery will not be able to keep up with the current draw and the battery life will be greatly reduced. [11]

Other battery specifications to consider when designing a PV system include the charge/discharge cycle history, ambient temperature, and battery age. Lead-Acid batteries must not be overcharged, in order to avoid hydrogen particles to separate from the oxygen. Overcharging will cause the battery to start gassing, which results in water loss. Water loss will decrease the battery's charging efficiency and reduce the battery's operating life. Similarly, Lead-Acid batteries should not be undercharged because undercharging makes them susceptible to freezing, which also shortens their operating life.

Any battery must be kept inside a certain temperature range to maximize the battery life, so long-term storage is another consideration that must be accounted for. Large batteries should be kept in a storage area where they can be heated or cooled depending on the climate and/or season.

Many PV, wind, or hybrid systems are "sized" or rated in terms of their battery capacity. Ideally, a battery bank should be sized to provide power to a load for up to five days during inclement weather conditions [6]. If the battery bank is smaller than a three day capacity, the battery will be deep-cycling on a regular basis, which will shorten its operating life.

Lead-acid batteries are used most frequently in PV systems, and various types include starting batteries, RV or marine "deep cycle" batteries, lead-calcium (Pb-Ca) batteries, and true deep-cycle batteries. A true deep-cycle battery is a battery that delivers on average a few amperes of current to the load for hundreds of hours between charges. In contrast, shallow-cycle batteries deliver hundreds of amperes to a load in a very quick amount of time and then the battery is recharged, making them ideal for automobile applications. The true deep-cycle battery is most reliable for PV systems, because when fully charged, it is recommended to use 50% of the batteries energy towards power the load before recharging [6]. This timing makes it ideal for PV applications, which rely on solar energy during the day and battery back-up at night. In case of an emergency – such as prolonged inclement weather – the battery charge may be reduced to 30%, but going below 20% too frequently will greatly reduce the battery life [6].

Many systems also incorporate a charge controller to assist in controlling the charging and discharging states of a battery. For example, a charge controller can be designed where the low voltage disconnect (LVD) will go into effect when the battery is going to fall below a 20% charge. When the LVD is engaged, the battery will be disconnected from the load until the battery has been charged to an appropriate level. A high voltage disconnect (HVD) also exists in charge controllers and is used to detect when the battery is fully charged. When a battery is fully charged, the HVD will go into effect and limit the amount of current that flows to the battery. True deep-cycle batteries are ideal for PV systems because they can go through hundreds or even thousands of cycles if the battery is properly cared for.

Batteries are the key element for the storage of extra power generated from renewable energy systems, and they are most critically useful in remote and rural locations where a grid connection is not available. The inclusion of a battery bank in any system's design will

ultimately save the consumer money as a long-term investment, because a fuel-consuming gas- or diesel-powered generator need not be relied upon as often in the event of bad weather.

It is important to note that when selecting batteries for any PV, wind, or hybrid system, the list of possible lead-acid, true deep-cycle batteries that can be used will be further differentiated by the relative size the system and the approximate number of kilowatt-hours (kWh) that a consumer plans to use the system for. In addition to battery storage capacity, PV system designers must be sensitive to both cost and physical space available, so it is likely that trade-offs will be made and compromises reached during the design phase of the system.

Flat Panel PV Array Simulation

When simulating the flat panel photovoltaic system, it is important to first consider the theory. In particular, the PV modules' equivalent circuit design, open-circuit voltage, and power and I-V curves under specified standard test conditions (STC). STC for a typical PV module is generally taken as 1000 W/m² irradiance, 25°C temperature, and 1.5AM air mass [3].

The equivalent circuit for a standard PV module (see Figure 6) is derived from the physics of current generation, but for the purposes of this simulation it is most important to consider the electrical calculations relating to the actual application in real systems.

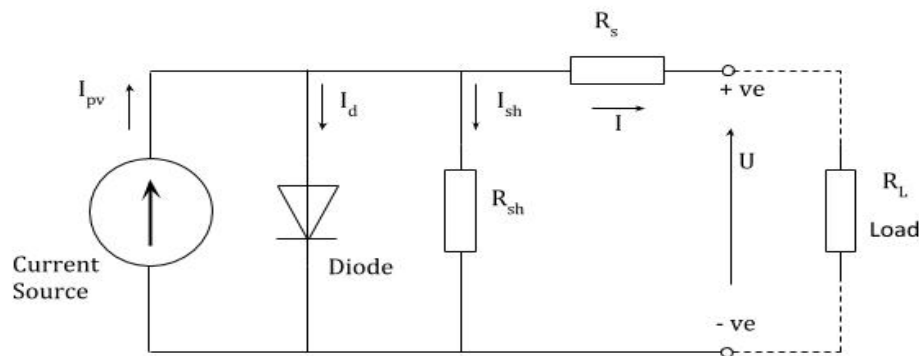

Figure 6: PV Module Equivalent Circuit

The PV module's characteristic equation – which solves for the module's open-circuit voltage (V_{OC}) – can be derived from the equivalent circuit shown above. Ultimately, this derivation yields:

$$V_{OC} = \left(\frac{nkT}{q} \right) \left(\ln \left(\frac{I_{SC}}{I_0} \right) + 1 \right)$$

For which: n = electron density; k = Boltzman constant; T = temperature; q = electric charge; I_{SC} = short-circuit current; and $I_0 = (\text{current density}) \times (\text{PV cell area}) = \text{output current}$.

A PV system's MPP is a variable quantity that depends on solar irradiance and cell temperature. It is best demonstrated by the unique power and I-V curves of any PV system. A system's I-V curve is obtained by varying an external resistance from zero (short-circuit) to

infinity (open-circuit) at STC. Power delivered by the PV cell is the product of current and voltage, so zero power is delivered at short-circuit and open-circuit points. This means the MPP must fall between the extremes.

The Matlab simulation performed utilized a pre-published, detailed example file for a grid-connected, flat panel PV system [3]. The example file was scripted for a 100-kW PV array connected to a 25-kV grid via a DC-DC boost converter and a three-phase (3φ), three-level (3L) VSC. When run in Simulink, the example file specified 66 parallel strings of 5 series-connected PV cells, with each cell capable of delivering a power output of 305.2-W at STC. Specifications also included: $V_{OC} = 64.2\text{-V}$; $I_{SC} = 5.96\text{-A}$; $V_{MPP} = 54.7\text{-V}$; and $I_{MPP} = 5.58\text{-A}$.

For the purpose of this project, the example file was modified such that it could simulate a 40-kW array with a 25-kV grid connection. These modifications were accomplished by varying the number of parallel strings of series-connected PV cells:

$$P_{out} = (305.2W)(\# strings)(\# series connected cells)$$

$$40,000W = (305.2W)(\# strings)(5 cells) \rightarrow 26.21 strings$$

Following this formula, the final simulation modeled 26 parallel strings, each of which contained five series-connected PV cells. Once parameters were established at STC, it was possible to ascertain the key values for the 26x5 array using the model given in Figure 7.

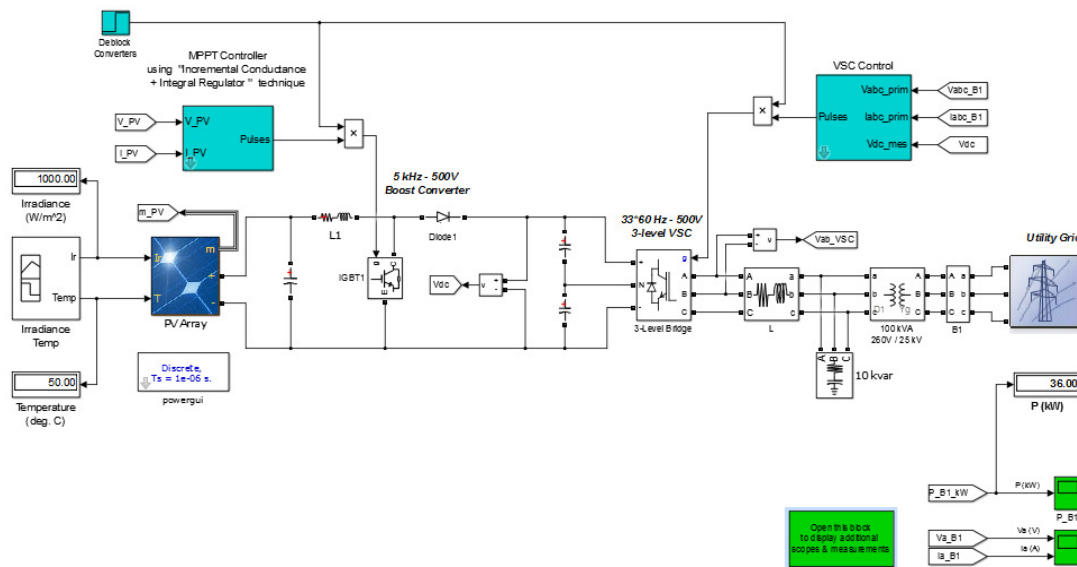

Figure 7: Final 40-kW PV Array with 25-kV Grid Tie-In

Over a period (T) of 2.5 seconds, the average output power generated by the system was approximately 36.0-kW, see Figure 8. This makes sense, as the measurement was taken between the boost converter and the grid; the grid can absorb 25.0 KW of power from the system, so the excess 11.0-KW in this example is wasted. To harness this excess power, the system could be expanded to include a battery back-up.

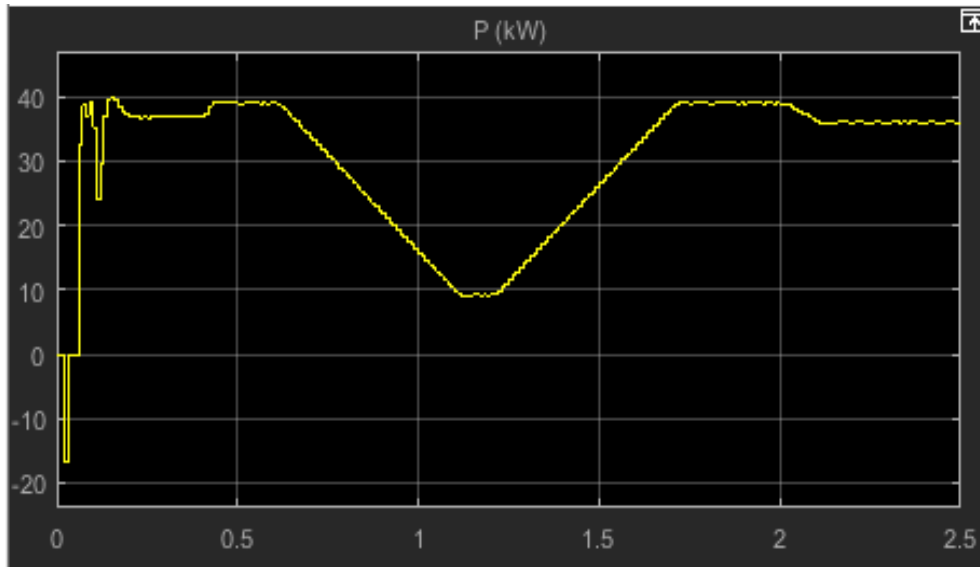

Figure 8: Simulink Scope for P_{out} at $T = 2.5s$

Furthermore, the simulation demonstrated a periodic (sinusoidal) current and a pulsating voltage at the VSC controller. This also makes sense; because the VSC block regulates the MPP of the system via pulse width modulation techniques that are applied as the three phases of voltage come off of the three-level bridge.

The experimental (traced) I_{MPP} value is easily verified by the system's characteristic equation:

$$\begin{aligned} \text{original } I_{MPP} &= 5.58A = (\text{current density } J)(66 \times 5) \\ \therefore \text{current density } J &= 0.0169 \\ \text{new } I_{MPP} &= (0.0169)(26 \times 5) = 2.198A \\ \% \text{ difference} &= \frac{|2.198 - 2.199|}{2.199} \times 100 = 0.0455\% \end{aligned}$$

Having verified the value of I_{MPP} given by the simulation, it is possible to further verify the values of V_{MPP} and P_{in} :

$$\begin{aligned} V_{MPP} &= \frac{P_{MPP}}{I_{MPP}} = \frac{36kW}{2.199A} = 16.4kV \\ \eta = \frac{P_{MPP}}{P_{in}} \rightarrow P_{in} &= \frac{P_{MPP}}{\eta} = \frac{36kW}{0.25} = 144.0kW \end{aligned}$$

For these calculations, the simulation value of $P_{MPP} = 36.0\text{-kW}$ is used, which differs from the desired system's $P_{MPP} = 40.0\text{-kW}$ by 4.0-kW due to the rounding-down of the number of PV cells in the array. Initial calculations indicated a need for 26.21 strings, but an integer number of 26 strings were used for the final model. Additionally, these calculations assumed the industry standard PV cell efficiency of $\eta = 25\%$, which was effectively determined for 2015 by the National Renewable Energy Laboratory.

Wind Turbine Simulation

An ideal wind turbine simulation begins with the theory – in this case, for a horizontal-axis turbine with generator back-up that is connected to a utility grid. The turbine's most important characteristic is the output power that it can generate, which is given by:

$$P_{out} [kW] = \frac{1}{2} (k C_p) (\rho A V^3)$$

For which: k = constant (0.000133); C_p = maximum power coefficient ($0.25 < C_p < 0.45$, theoretical maximum at 0.59); ρ = air density in lbs/ft³; A = area swept out by rotor blades in ft²; and V = wind speed in mph [4]. The portion that is available as input power to the turbine is:

$$P_{in} [kW] = \frac{1}{2} (\rho A V^3)$$

This in turn influences the maximum possible efficiency of the turbine, which is calculated as a ratio of the output and input power, or as a ratio of the air speed on either side of the turbine blades. Assuming the general case of a horizontal-axis machine of unknown height, with three blades spaced at 120° intervals, all with negative blade tilt angles, the efficiency is calculated as:

$$\eta = \frac{v_{air \text{ out of turbine}}}{v_{air \text{ into turbine}}} = \frac{P_{out}}{P_{in}} = \frac{\frac{1}{2} (k C_p) (\rho A V^3)}{\frac{1}{2} (\rho A V^3)} = k C_p$$

$$k C_p \approx 0.33 = 33\%$$

Thus, the maximum possible efficiency of a generalized horizontal-axis wind turbine is significant because it does not depend directly on the wind's velocity and cannot exceed 33%.

In specific cases when the exact dimensions and specifications of a wind turbine and its environment are known, the constant k is dependent on blade pitch angle and wind speed, via the turbine's tip speed ratio. Tip speed ratio is the ratio of the rotor blade tip speed to the wind speed. The system's efficiency for this specific case is calculated as:

$$k = \lambda \beta = \left(\frac{v_{rotor \text{ blades}}}{v_{wind}} \right) (\text{blade tilt angle [deg]})$$

$$0.25 < C_p < 0.45 \text{ (max @ 0.59)}$$

$$\eta = k C_p = \frac{(v_{rotor \text{ blades}})(\beta)(C_p)}{v_{wind}}$$

The specific case efficiency is significant because it takes into account all factors that could influence the wind turbine's functional capabilities. As the wind speed increases, the rotor

speed increases, thus increasing the efficiency of the turbine. Greater wind speeds can be found at higher altitudes, which accounts for the increasing tower heights of many commercial wind turbines. The conditions of the specific case system yield a detailed power curve that is widely accepted for all commercial wind turbine applications.

The Matlab simulation performed for the wind turbine system utilized a pre-published, detailed example file [4]. The example file is scripted for a horizontal-axis wind turbine with generator back-up that is connected to a utility grid at 75-kW.

The simulation was run on the example file without modifications; the desired power output (P_{out}) was equal to the nominal mechanical output power of 1.5-MW.

Over a period (T) of 60 seconds, the wind speed followed an exact parabolic fit to $y = \frac{1}{20}(x - 30)^2 + 25$, meaning that: (1) the maximum wind speed of 25-m/s was reached at 1/2 of the period (30-sec), and (2) the power output was a step function relative to wind speed.

Because the simulation assumes the general model of the wind turbine, it is presumable that its maximum possible efficiency is 33%. The efficiency of the generator – calculated as $\frac{P_{generator}}{P_{turbine}}$ – is 90% [4]. Using the turbine's efficiency equation and the trace measurements on the wind speed curve, it is possible to calculate both the maximum speed of the wind exiting the turbine and the maximum input power of the turbine at its peak efficiency:

$$\eta: (0.33)(25 \text{ m/s}) = 8.25 \text{ m/s} = v_{air \text{ out of turbine}}$$

$$\eta: \frac{150 \text{ kW}}{0.33} = 454.5 \text{ kW} = P_{in}$$

It is difficult to calculate any other characteristic properties of the wind turbine (tip speed ratio, area swept out by rotor blades, etc.) without having more data regarding the machine's physical features. If more data were known, it would be possible to employ the specific case equations for turbine efficiency, which could ultimately lead to a more thorough evaluation and verification of the simulated system.

Hybrid System Simulation with Grid Connection

The hybrid system operates on dual three-phase, 60Hz input signals. The wind turbine inputs an AC signal, while the PV array inputs a DC signal that must be inverted prior to the load bus. The two AC signals are joined at the load bus, which feeds into the main grid and/or an alternate AC load given in Figure 9.

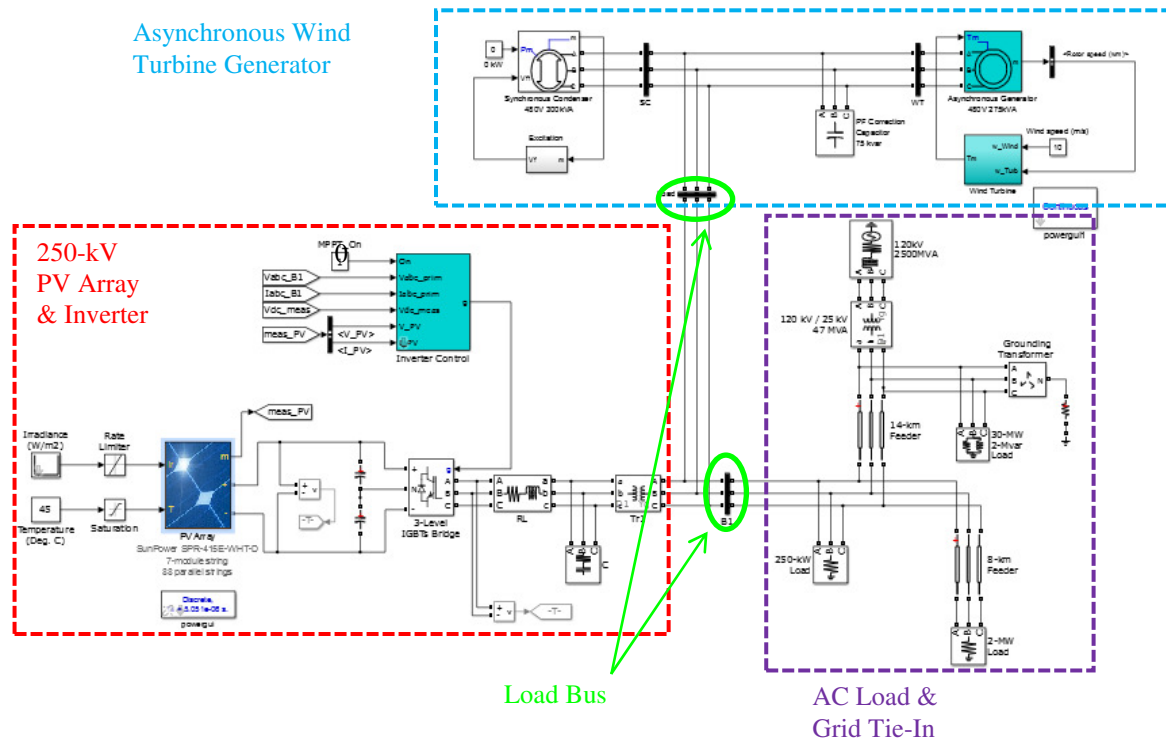

Figure 9: Complete Simulink Model of the Hybrid System

The hybrid model outputs a significant amount of data to the Matlab workspace, which is vital for system analysis and proof of concept before construction.

To prove the hybrid model's precision, separate simulations were run for the PV array and the wind turbine, with each being simulated under stand-alone and grid-connected conditions. In all four of these cases, the Simulink model compiled and the simulation ran smoothly and without errors. The four individual results verify the precision of the hybrid system, if the hybrid system is considered as the sum of its parts.

Conclusion

The project accomplished its main objectives for background research and simulation of PV, wind, and hybrid renewable energy systems. Each system was designed as a microgrid that is capable of operating in parallel with or independent from the main electrical grid. A connection to the main grid was not required for this project, but it was simulated for each system – (PV, wind, and PV-wind hybrid) in order to thoroughly verify the integrity of each system's design.

The simulation results for the PV and wind systems were conclusive. The 40-kW PV system yielded $I_{MPP} = 2.198\text{-A}$, $V_{MPP} = 16.4\text{-kV}$, and $P_{MPP} = 36.0\text{-kW}$, under the assumed conditions of 25% efficiency for all PV cells. The 150-kW (P_{out}) wind system yielded wind speeds of

17.68-m/s (in) and 8.25-m/s, and an input power of 454.5-kW. When the PV side of the system was separated from the wind side of the system, and when each was run as its own simulation, the two simulations yielded conclusive results similar to those of the stand-alone systems. This proves that the hybrid system model is complete and would yield a conclusive result if it were to be run on a full license of Matlab.

The hybrid system simulation results dictate the specifications of components that must be chosen in order for the system to be constructed and implemented. The most important (and most restrictive) of these components are the PV array, wind turbine, and renewable energy converter. Based on these results, a set of assumptions could be made about the system's operating conditions, which would allow for components to be chosen for a "hypothetical construction."

References

- [1] Hart, Daniel W. *Introduction to Power Electronics*. Prentice Hall. 1st Edition; 1996.
- [2] Hui, Joanne; Alireza Bakhshai; Praveen Jain. "A Hybrid Wind-Solar Energy System: A New Rectifier Stage Topology." *IEEE Student Publications*. Queen's University. Kingston, Ontario, Canada. Electronic publication.
<http://www.ee.bgu.ac.il/~pedesign/Graduate_problem_papers/Papaers_2010/Hybrid%20Wind-Solar%20Energy%20System.pdf>
- [3] The MathWorks, Inc. "Three-Phase Asynchronous Wind Turbine Generator." Online. Accessed 28 June 2016. <<http://www.mathworks.com/help/physmod/sps/examples/three-phase-asynchronous-wind-turbine-generator.html>>
- [4] Morra, James. "Multi-Input Power Converter Will Upgrade Renewable Energy Networks." *Electronic Design*. Online. Published 10 June 2015. Accessed 08 June 2016. <<http://electronicdesign.com/power/multi-input-power-converter-will-upgrade-renewable-energy-networks>>
- [5] "PV Battery: Photovoltaic System Component." Solar Direct, Inc. Online. Accessed 17 June 2016. <<http://www.solardirect.com/pv/batteries/batteries.htm>>
- [6] US Department of Energy. "Hybrid Wind and Solar Electric Systems." Online. Accessed 07 June 2016. <<http://energy.gov/energysaver/hybrid-wind-and-solar-electric-systems>>
- [7] Rashid, Muhammad H. *Power Electronics: Circuits, Devices, and Applications*. Upper Saddle River NJ, USA: Pearson Educational Press. 4th Edition; 2014. Print.
- [8] Reid, R.; B. Saulnier; R. Gagnon. "Wind Turbine Asynchronous Generator in Isolated Network." Hydro-Quebec (IREQ). Online. Accessed 16 June 2016.

<http://www.mathworks.com/help/physmod/sps/examples/wind-turbine-asynchronous-generator-in-isolated-network.html>>

[9] Steeby, Donald L. *Alternative Energy: Sources and Systems*. The Green Destination Series. Clifton Park NY, USA: Delmar Cengage Learning. 1st Edition; 2012. Print.

[10] Sumathi, S.; L. Ashok Kumar; P. Surekha. *Solar PV and Wind Energy Conversion Systems: An Introduction to Theory, Modeling with MATLAB/SIMULINK, and the Role of Soft Computing Techniques*. Switzerland: Springer International Publishing. 1st Edition; 2015. Print.

[11] Wind Energy Basics.” US Wind Energy Development Program EIS. Online. Accessed 14 June 2016. <<http://windeis.anl.gov/guide/basics/>>

Biographies

DOMINICK LAURIA is currently a Graduate Student and Lab Instructor in Electrical Engineering at the University of Hartford. He has earned a B.S. degree in Audio Engineering Technology from the University of Hartford. He has one year of industry experience in audio and electronic equipment repair. He may be reached at dlauria@hartford.edu.

SARAH LAMB is currently a Graduate Student in Electrical Engineering and Business Administration at the University of Hartford. Ms. Lamb earned a B.S. degree in Physics from the University of Connecticut and taught AP/IB Physics and Robotics extensively at the secondary school level before returning to graduate school full-time. She is also a professional race mechanic with USA Cycling. She may be reached at slamb@hartford.edu.

AKRAM ABU-AISHEH is an Associate Professor of Electrical and Computer Engineering at the University of Hartford. Professor Abu-aisheh is a senior IEEE member, and he has ten years of industry experience in the area of fiber optic telecommunication systems and power electronics. Professor Abu-aisheh’s research interests include optical communications and power electronics. Professor Abu-aisheh has M.S. and B.S. degrees in Electrical Engineering from the University of Florida and a Ph.D. in Electrical Engineering from the Florida Institute of Technology. Professor Abu-aisheh can be reached via email at abuaisheh@hartford.edu